

### Fire Fighting Hydrant Valve Straight

Fig. 9132 | FIRE FIGHTING HYDRANT VALVE DECK WASH STRAIGHT FLANGED - BRONZE - PN10 / PN16 - DN40 to DN65

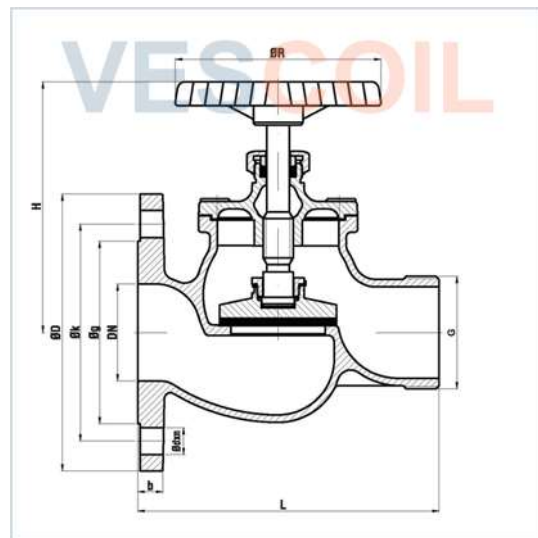

#### DOCUMENTATION

Fig:	9132
Class & Approvals:	On request
Norm:	EN (DIN)
Construction:	Straight
Size:	DN40 to DN65 (1 1/2" up to 2 1/2")
Working Pressure:	PN10 / PN16
Temperature:	-10°C to +120°C
Connection 1:	Flanged
Connection 2:	Storz coupling (other on request)
Cam distance:	See overview
Sealing:	EPDM
Markets:	Maritime / Offshore / Industry / Energy / Petrochemical
Used in:	Water
Material body:	Bronze - RG5
Material disc:	Bronze - RG5
Material bonnet :	Bronze - RG5

Material stem: Brass - CuZn39Pb3/MS58  
 Material gasket: Klingerit  
 Material Packing: Graphite  
 Material wheel: Cast Iron - GG25

### MAIN DIMENSIONS

DN	∅D	∅k	∅g	b	∅dxn	L	H	∅R	G	KG
40	150	110	88	18	18x4	150	130	110	R 1 1/2"	5,4
50	165	125	102	20	18x4	165	140	140	R 2"	6,8
65	185	145	122	20	18x4	200	160	140	R 2 1/2"	9

*Information can be manufacture dependent.*

Cam distance		Connection
31 mm	x	1"
44 mm	x	1 1/4"
52 mm	x	1 1/2"
66 mm	x	1 1/2"
66 mm	x	2"
81 mm	x	2"
81 mm	x	2 1/2"
81 mm	x	3"
89 mm	x	2 1/2"
89 mm	x	3"
115 mm	x	4"
133 mm	x	4"

### TECHNICAL DRAWING

