

## Captive Spring Hanger Type SH

Fig. 9372 | SPRING HANGER - TYPE SH - 10KG – 500KG – M8 TO M16

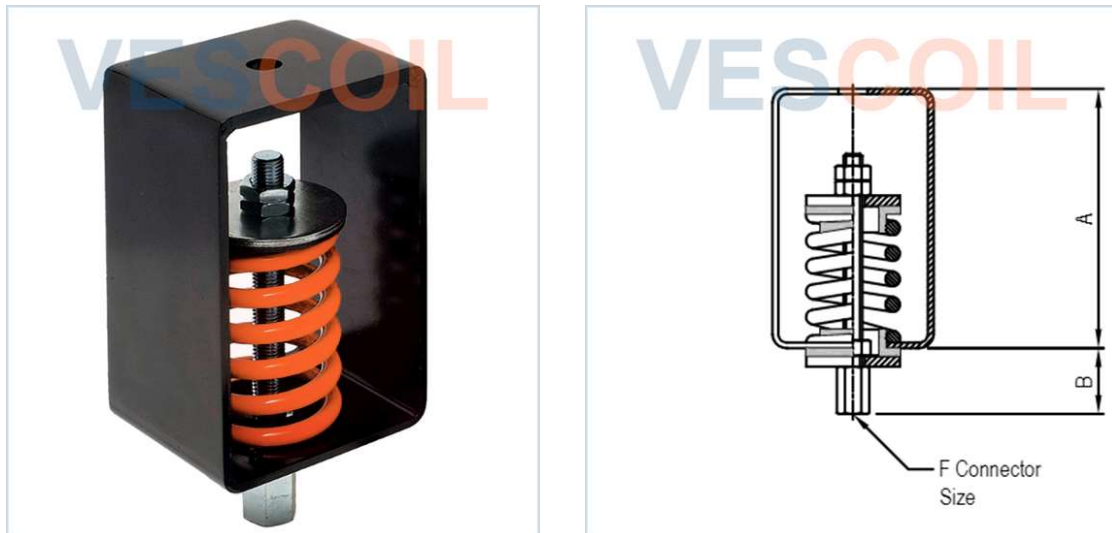

### DOCUMENTATION

A comprehensive range of steel spring hangers offering low frequency vibration isolation. Wide load ranges and fixing requirements are catered for. Specialist hangers combining steel springs and rubber elements are available and also higher deflection springs if required

### DESIGN FEATURES

- Epoxy powder coated steel frame tested to 5 x rated load. Other steel parts are zinc plated.
- Colour coded helical steel springs to BS1726 Class B with nominal deflections up to 50 mm, laterally stable with 50% overload capacity.
- Rubber inserts for high frequency attenuation on Type SH also prevent drop rod contacting hanger frame.
- Captive assembly with drop rod connector on Type SH allows precompression of spring prior to installation if required.
- Capable of up to 15° angular misalignment.
- Can be fitted in drop rod or direct to supporting structure.

### TYPICAL APPLICATIONS

- Pipework.
- Axial Fans and Fan Coil Units.
- Ductwork and Attenuators.
- Exhaust Systems.
- Acoustic Ceilings.
- Any other suspended plant.

PIPE BORE (mm)	WEIGHT per METRE (kg)	LOAD per HANGER AT TYPICAL SPACINGS (kg)						
		2 m	2.5 m	3 m	3.5 m	4 m	4.5 m	5 m
50	10	20	25	30	-	-	-	-
65	14	28	35	42	49	-	-	-
80	18	36	45	54	63	-	-	-
100	26	52	65	78	91	-	-	-
125	34	68	85	102	119	136	-	-
150	44	88	110	132	154	176	-	-
200	86	172	215	258	301	344	387	-
250	118	236	295	354	413	472	531	590
300	153	306	382	459	535	612	689	765

Pipe weights are based on BS EN 10255, BS EN 10216-1 and BS EN 10217-1 for pipes with maximum volume of water and standard thermal insulation.

PART No.	COLOUR CODE	RATED LOAD(kg)	DEFLECTION AT RATED LOAD (mm)	DIMENSIONS (mm)						MAXWT (kg)
				A	B	C	D	E	F	
SH20/10	PURPLE	10	20							
SH20/15	YELLOW	15	20							
SH20/20	GREY	20	20	100	30.5	40	55	10	M8	0.35
SH20/40	GREEN	40	20							
SH20/70	RED	70	20							
SH15/100	BLUE	100	15							
SH30	YELLOW	30	25							
SH60	GREEN	60	30							
SH100	BLUE	100	25	140	36	70	90	11	M10	1.5
SH160	WHITE	160	25							
SH250	RED	250	25							
SH200	RED	200	25							
SH300	PURPLE	300	25							
SH400	GREY	400	25	200	54	95	120	17	M16	4.2
SH500	ORANGE	500	25							
SH600	BROWN	600	25							
SH800	BLACK	800	25							
SH50/100	YELLOW	100	50							
SH50/200	GREEN	200	50							
SH50/300	BLUE	300	50	200	54	95	120	17	M16	4.2
SH50/400	WHITE	400	50							
SH50/500	RED/BLACK	500	50							

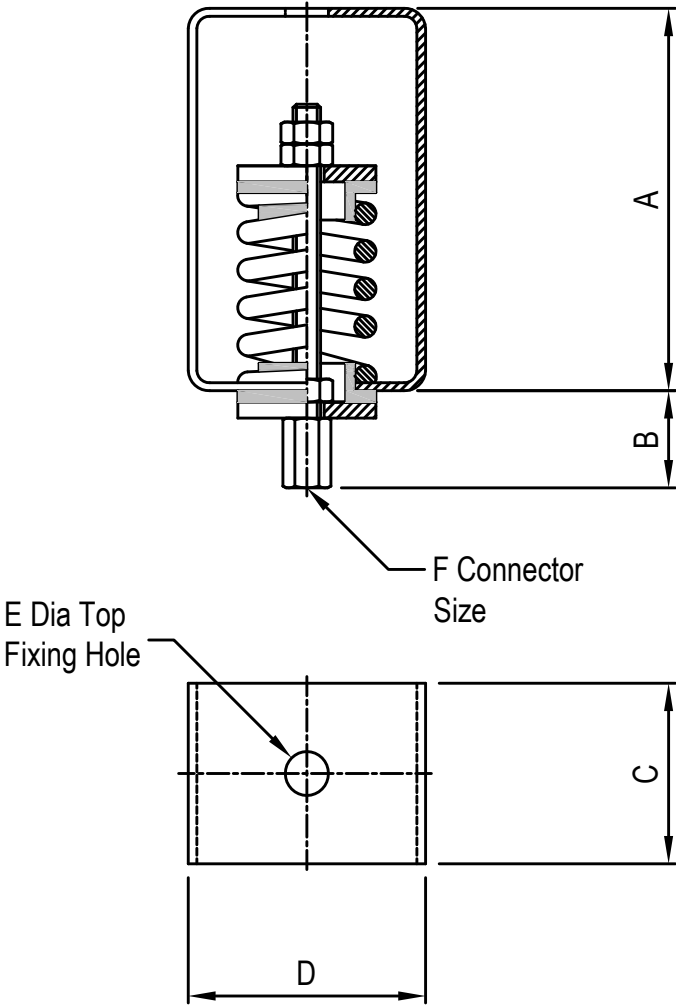

A comprehensive range of steel spring hangers offering the designer optimum performance for low frequency vibration isolation.

Wide load ranges and fixing requirements are catered for. Specialist hangers combining steel springs and rubber elements are available and higher deflection springs if required.

**Installation Notes:**

Pipes should be supported on either side of changes of direction and additional hangers used to support heavy fittings and vertical droppers.

For larger pipe sizes two hangers can be used at each support position.